

StorageLynx 1394 Link-Layer Controller for ATA/ATAPI Storage Products

FEATURES

- Serial bus data rates of 100, 200, and 400 Mbps
- IEEE P1394a compliant and IEEE Std 1394-1995
- Automated SBP-2 transport protocol engine
- ATA/ATAPI command translation by embedded processor and firmware
- Programmable ATA/ATAPI interface supporting PIO modes 0–4, DMA modes 0–2, and Ultra DMA modes 0–4
- Automated 1394 and SBP-2 header removal and insertion
- Internal parameter RAM for fast access to configuration ROM and key SBP-2 parameters
- Automatic response to configuration ROM quadlet and block read requests
- External flash PROM / EPROM interface for easy program code changes during prototyping
- Separate address and data busses for the external flash PROM / EPROM interface (no external latches)
- 16K internal ROM program memory
- 576 Byte (128 quadlet) transmit control FIFO, 576 byte (128 quadlet) receive control FIFO
- Bidirectional data FIFO
- 0.18 micron CMOS technology with embedded RAM and ROM
- Space-saving 100 pin TQFP package

DESCRIPTION

The Texas Instruments TSB42AA9 (StorageLynx) is a 1394 Link Layer Controller designed to function as a native bridge between the 1394 bus and ATA (AT Attachment) or ATAPI (AT Attachment with Packet Interface) data storage applications. These data storage devices can include external hard disk drives (HDDs), ZIP drives, magneto-optical (MO) drives, ORB drives, CD-ROMs, CD-R/Ws, DVD-ROMs, and DVD-RAMs. The ATA/ATAPI interface of the TSB42AA9 supports signaling and timing for programmed input/output (PIO) modes 0–4, direct memory access (DMA) modes 0–2, and Ultra DMA modes 0–4. The 1394 interface of StorageLynx is IEEE P1394a⁽¹⁾ and IEEE Std 1394-1995⁽²⁾ compliant and supports 400, 200, and 100 Mbps serial bus data rates.

StorageLynx is particularly designed for any data storage application that supports the SBP-2⁽³⁾ (Serial Bus Protocol 2) transaction layer as a target device. The TSB42AA9 automates the SBP-2 target controller functions by implementing the management and command agents in hardware. Data handling is also executed in hardware, with no assistance from the processor needed to setup a DMA transaction to fetch data from the ATA/ATAPI device and return it to the SBP-2 initiator via the 1394 bus. StorageLynx translates SBP-2 protocol commands to ATA/ATAPI commands using the hardware-implemented functions and an embedded 8052 processor executing firmware. The firmware is located in the internal ROM of the device or optionally, an external memory location.

A 2-wire serial bus interface is included on the TSB42AA9. This interface enables configuration ROM information required by IEEE Std 1394-1995⁽²⁾ and SBP-2 to be loaded from a serial EEPROM into the device's internal parameter RAM. The internal parameter RAM allows StorageLynx faster access to important configuration information as well as automatic responses to configuration ROM read requests from the system host. In addition, StorageLynx provides a memory interface which can be used to access firmware from an external Flash PROM/EPROM for testing and development purposes, or to support storage applications which require specialized functionality. The StorageLynx memory interface also supports write operations to the Flash PROM/EPROM, removing the need for parts to be in sockets and allowing for easy software downloads. Flash memory is not required unless custom functionality and in-system reprogrammability are requirements.

(1) IEEE Std 1394–1995, Standard for a High Performance Serial Bus
(2) NCITS T10 1240D, Reduced Block Commands Revision 10 (RBC)
(3) T10 Project 1155D, ANSI NCTIS.xxx–199x, Serial Bus Protocol 2 (SBP-2)



Please be aware that an important notice concerning availability, standard warranty, and use in critical applications of Texas Instruments semiconductor products and disclaimers thereto appears at the end of this data sheet.

NOTE:

This product is for high-volume PC applications only. For a complete datasheet or more information contact support@ti.com.

PACKAGING INFORMATION

Orderable Device	Status ⁽¹⁾	Package Type	Package Drawing	Pins	Package Qty	Eco Plan ⁽²⁾	Lead/Ball Finish	MSL Peak Temp ⁽³⁾
TSB42AA9PZT	OBSOLETE	TQFP	PZT	100		TBD	Call TI	Call TI
TSB42AA9PZTR	OBSOLETE	TQFP	PZT	100		TBD	Call TI	Call TI

⁽¹⁾ The marketing status values are defined as follows:

ACTIVE: Product device recommended for new designs.

LIFEBUY: TI has announced that the device will be discontinued, and a lifetime-buy period is in effect.

NRND: Not recommended for new designs. Device is in production to support existing customers, but TI does not recommend using this part in a new design.

PREVIEW: Device has been announced but is not in production. Samples may or may not be available.

OBSOLETE: TI has discontinued the production of the device.

⁽²⁾ Eco Plan - The planned eco-friendly classification: Pb-Free (RoHS), Pb-Free (RoHS Exempt), or Green (RoHS & no Sb/Br) - please check <http://www.ti.com/productcontent> for the latest availability information and additional product content details.

TBD: The Pb-Free/Green conversion plan has not been defined.

Pb-Free (RoHS): TI's terms "Lead-Free" or "Pb-Free" mean semiconductor products that are compatible with the current RoHS requirements for all 6 substances, including the requirement that lead not exceed 0.1% by weight in homogeneous materials. Where designed to be soldered at high temperatures, TI Pb-Free products are suitable for use in specified lead-free processes.

Pb-Free (RoHS Exempt): This component has a RoHS exemption for either 1) lead-based flip-chip solder bumps used between the die and package, or 2) lead-based die adhesive used between the die and leadframe. The component is otherwise considered Pb-Free (RoHS compatible) as defined above.

Green (RoHS & no Sb/Br): TI defines "Green" to mean Pb-Free (RoHS compatible), and free of Bromine (Br) and Antimony (Sb) based flame retardants (Br or Sb do not exceed 0.1% by weight in homogeneous material)

⁽³⁾ MSL, Peak Temp. -- The Moisture Sensitivity Level rating according to the JEDEC industry standard classifications, and peak solder temperature.

Important Information and Disclaimer:The information provided on this page represents TI's knowledge and belief as of the date that it is provided. TI bases its knowledge and belief on information provided by third parties, and makes no representation or warranty as to the accuracy of such information. Efforts are underway to better integrate information from third parties. TI has taken and continues to take reasonable steps to provide representative and accurate information but may not have conducted destructive testing or chemical analysis on incoming materials and chemicals. TI and TI suppliers consider certain information to be proprietary, and thus CAS numbers and other limited information may not be available for release.

In no event shall TI's liability arising out of such information exceed the total purchase price of the TI part(s) at issue in this document sold by TI to Customer on an annual basis.

PZT (S-PQFP-G100)

PLASTIC QUAD FLATPACK

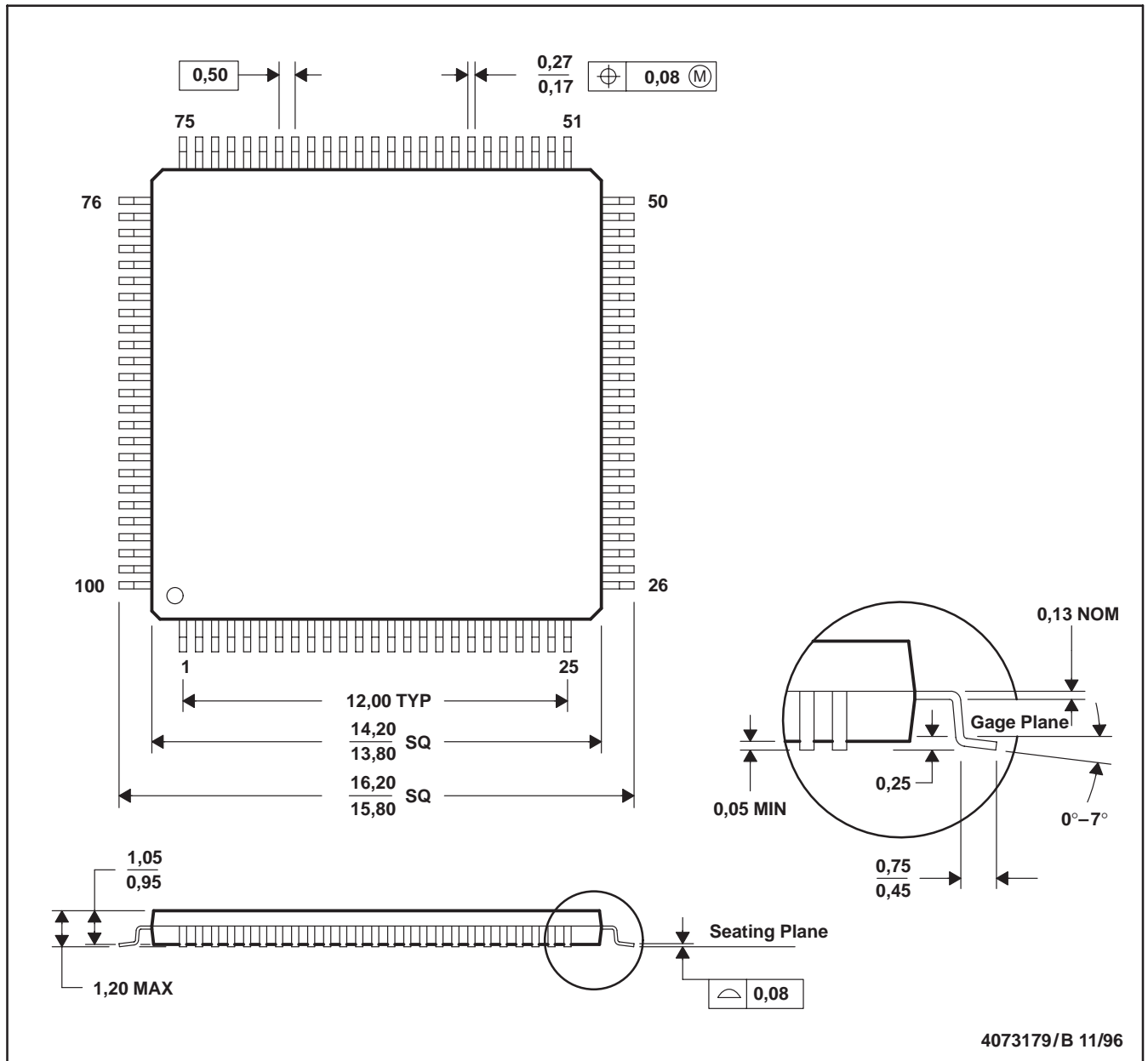

- NOTES: A. All linear dimensions are in millimeters.
 B. This drawing is subject to change without notice.
 C. Falls within JEDEC MS-026

IMPORTANT NOTICE

Texas Instruments Incorporated and its subsidiaries (TI) reserve the right to make corrections, modifications, enhancements, improvements, and other changes to its products and services at any time and to discontinue any product or service without notice. Customers should obtain the latest relevant information before placing orders and should verify that such information is current and complete. All products are sold subject to TI's terms and conditions of sale supplied at the time of order acknowledgment.

TI warrants performance of its hardware products to the specifications applicable at the time of sale in accordance with TI's standard warranty. Testing and other quality control techniques are used to the extent TI deems necessary to support this warranty. Except where mandated by government requirements, testing of all parameters of each product is not necessarily performed.

TI assumes no liability for applications assistance or customer product design. Customers are responsible for their products and applications using TI components. To minimize the risks associated with customer products and applications, customers should provide adequate design and operating safeguards.

TI does not warrant or represent that any license, either express or implied, is granted under any TI patent right, copyright, mask work right, or other TI intellectual property right relating to any combination, machine, or process in which TI products or services are used. Information published by TI regarding third-party products or services does not constitute a license from TI to use such products or services or a warranty or endorsement thereof. Use of such information may require a license from a third party under the patents or other intellectual property of the third party, or a license from TI under the patents or other intellectual property of TI.

Reproduction of TI information in TI data books or data sheets is permissible only if reproduction is without alteration and is accompanied by all associated warranties, conditions, limitations, and notices. Reproduction of this information with alteration is an unfair and deceptive business practice. TI is not responsible or liable for such altered documentation. Information of third parties may be subject to additional restrictions.

Resale of TI products or services with statements different from or beyond the parameters stated by TI for that product or service voids all express and any implied warranties for the associated TI product or service and is an unfair and deceptive business practice. TI is not responsible or liable for any such statements.

TI products are not authorized for use in safety-critical applications (such as life support) where a failure of the TI product would reasonably be expected to cause severe personal injury or death, unless officers of the parties have executed an agreement specifically governing such use. Buyers represent that they have all necessary expertise in the safety and regulatory ramifications of their applications, and acknowledge and agree that they are solely responsible for all legal, regulatory and safety-related requirements concerning their products and any use of TI products in such safety-critical applications, notwithstanding any applications-related information or support that may be provided by TI. Further, Buyers must fully indemnify TI and its representatives against any damages arising out of the use of TI products in such safety-critical applications.

TI products are neither designed nor intended for use in military/aerospace applications or environments unless the TI products are specifically designated by TI as military-grade or "enhanced plastic." Only products designated by TI as military-grade meet military specifications. Buyers acknowledge and agree that any such use of TI products which TI has not designated as military-grade is solely at the Buyer's risk, and that they are solely responsible for compliance with all legal and regulatory requirements in connection with such use.

TI products are neither designed nor intended for use in automotive applications or environments unless the specific TI products are designated by TI as compliant with ISO/TS 16949 requirements. Buyers acknowledge and agree that, if they use any non-designated products in automotive applications, TI will not be responsible for any failure to meet such requirements.

Following are URLs where you can obtain information on other Texas Instruments products and application solutions:

Products		Applications	
Amplifiers	amplifier.ti.com	Audio	www.ti.com/audio
Data Converters	dataconverter.ti.com	Automotive	www.ti.com/automotive
DSP	dsp.ti.com	Broadband	www.ti.com/broadband
Interface	interface.ti.com	Digital Control	www.ti.com/digitalcontrol
Logic	logic.ti.com	Military	www.ti.com/military
Power Mgmt	power.ti.com	Optical Networking	www.ti.com/opticalnetwork
Microcontrollers	microcontroller.ti.com	Security	www.ti.com/security
RFID	www.ti-rfid.com	Telephony	www.ti.com/telephony
Low Power Wireless	www.ti.com/lpw	Video & Imaging	www.ti.com/video
		Wireless	www.ti.com/wireless

Mailing Address: Texas Instruments, Post Office Box 655303, Dallas, Texas 75265
Copyright © 2007, Texas Instruments Incorporated